

Electronic thermostats

AROS

Series of flush-mounting touch screen electronic thermostats on 3 modules 503 box designed for temperature control both in heating and cooling, available both in AC power supply and battery.



- 1 Installation in flush mounting 3 modules box (503 type)
- 2 Supports to adjust the instrument to the the most common civil series plates
- 3 Touch screen display to view the measured temperature and for the programming of the instrument
- 4 Terminals in the back of the instrument for connection to the relay output, power supply (Aros 230 only) and external contact (Aros only)
- 5 Interchangeable front panel available in white and anthracite grey colours (included in the package) and silver (you can buy it on request)
- 6 Display with backlighting:
 - multicolour red, green, blue for Aros 230
 - monocolour blue on with a touch for Aros



FLUSH-MOUNTING TOUCH SCREEN THERMOSTATS

- Power supply:
 - 230Vac 50/60 Hz for Aros 230 model
 - 2x1.5 V (AAA type) for Aros model
- Operating mode summer/winter/OFF
- ON/OFF type regulation with adjustable differential
- Off function with antifreeze temperature (adjustable)
- Bistable relay output with 5 A change-over contact (250 Vac)
- Password protected lock keypad
- Possibility to limit the range of values settable as the setpoint
- Input for free voltage contact for the reduction of the setpoint of 3°C (batteries Aros only)

Adjustable plates

- | | |
|----------------------------|---------------------------------|
| ABB Chiara series | Bticino Livinglight Air series* |
| ABB Mylos series | Bticino Matix series |
| Ave S44 series | Gewiss Chorus series |
| Bticino Axolute series | Vimar Eikon series |
| Bticino Light series | Vimar Eikon Evo series |
| Bticino Light tech series | Vimar Idea series |
| Bticino Living series | Vimar Plana series |
| Bticino Livinglight series | Vimar Arké series |

* by mount you can buy on request (code VE470100)

For information about the possibility to use different plates contact the technical assistance

Code	Model	Description	Colour	Power supply
VE459400	Aros 230	Touch screen thermostat with multicolour display	White/Grey	230 V~
VE458600	Aros	Touch screen thermostat with backlit display	White/Grey	Batteries
VE469300	Fr.Aros 230	Silver painted front panel for Aros 230	Silver	
VE762800	Fr.Aros	Silver painted front panel for Aros	Silver	
VE470100	AIR	Mount for Bticino Livinglight Air series plate		

DIMENSIONS (mm)

Front view

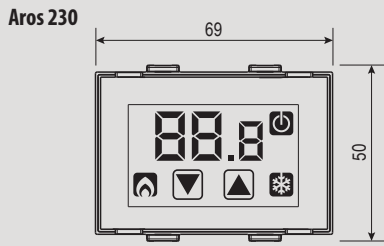

Aros

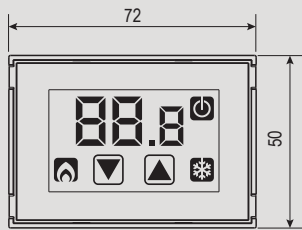

Side view

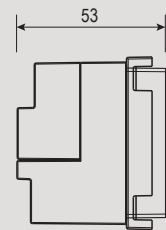
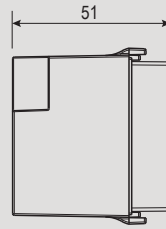

CONNECTION DIAGRAM

Diagram

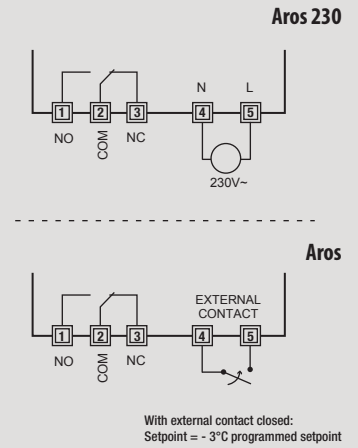

CLIMATE CONTROL

TECHNICAL INFORMATION

GENERAL CHARACTERISTICS

Aros 230

Power supply	V AC	230 (-15% ÷ +10%)
Frequency	Hz	50/60
Mounting		flush
Maximum cables section	mm ²	1.5
Output relay capacity		5A / 250 V (bistable)
Input		-
Operating mode		summer/winter/off
Setpoint range	°C	2 ÷ 35
Differential	°C	0.1 ÷ 1
Measurement temperature resolution	°C	0.1
Measurement precision	°C	0.5
Antifreeze temperature	°C	1 ÷ 10
Operating temperature	°C	0 ÷ 50
Storage temperature	°C	-10 ÷ 65
Operating humidity	RH	20% ÷ 90% non condensing
Protection degree		IP40

Aros

Alkaline batteries power supply		2 x 1.5V (AAA)
Battery life	months	12
Mounting		flush
Maximum cables section	mm ²	1.5
Output relay capacity		5A / 250 V (bistable)
Input		two terminals for setpoint reduction
Operating mode		summer/winter/off
Setpoint range	°C	2 ÷ 35
Differential	°C	0.1 ÷ 1
Measurement temperature resolution	°C	0.1
Measurement precision	°C	0.5
Antifreeze temperature	°C	1 ÷ 10
Operating temperature	°C	0 ÷ 50
Storage temperature	°C	-10 ÷ 65
Operating humidity	RH	20% ÷ 90% non condensing
Protection degree		IP40

REFERENCE STANDARDS

Compliance with Community Directives: 2014/35/EU (LVD) and 2014/30/EU (EMCD) is declared with reference to the following standards: • EN 60730-2-9