

Level switches

MAC5

Immersed tilting level switches. The essential feature is to have a heavy, voluminous and free of any irregularity body which is ideal for use in sewage water, in industrial waste water with suspended agglomerate residues and in turbulent water. The polypropylene body is made with a double airtight chamber and with a re-injection sealing of melted polypropylene at high pressure to ensure perfect sealing capacity against infiltrations.



SWITCHES FOR DARK WATER

- Breaking capacity: 10(3)A / 250 Vac
- Switching angle: $\pm 45^\circ$
- Resistance to pressure: 2 bar
- Available with PVC or neoprene cable and with various lengths
- Operating temperature: $0 \div +50^\circ\text{C}$
- Storage temperature: $-20 \div +80^\circ\text{C}$
- Protection degree: IP68
- Dimensions: 177x222 mm
- Weight / Volume: 1100 g / 1000 cm³
- ENEC approval



MEASUREMENT AND CONTROL

CONNECTION DIAGRAM

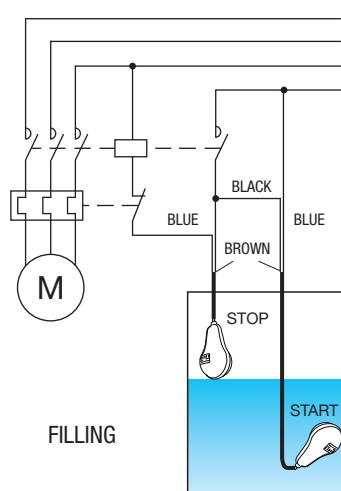

FILLING

⚠ ATTENTION
The cable which is not used must be properly isolated (brown for filling blue for emptying)

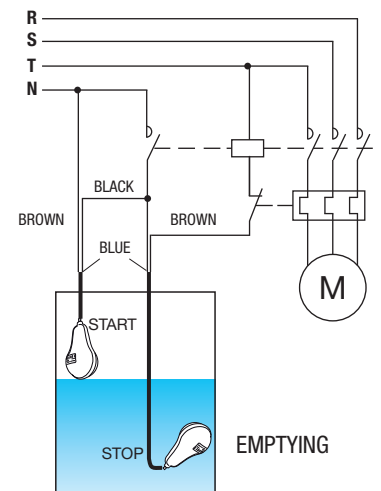

EMPTYING

Code	Model	Description	Cable type	Length (m)
VE515300	MAC5	Tilting level switch for dark water	Neoprene H07RN-F 3x1	5
VE516100	MAC5	Tilting level switch for dark water	Neoprene H07RN-F 3x1	10
VE517900	MAC5	Tilting level switch for dark water	Neoprene H07RN-F 3x1	20
VE518700	MAC5	Tilting level switch for dark water	PVC H05VV-F 3x1	5
VE519500	MAC5	Tilting level switch for dark water	PVC H05VV-F 3x1	10
VE520300	MAC5	Tilting level switch for dark water	PVC H05VV-F 3x1	20