

Level switches

MAC5 ATEX

Immersed tilting level switches with ATEX approval. The essential feature is to have a heavy, voluminous and free of any irregularity body which is ideal for use in sewage water, in industrial waste water with suspended agglomerate residues and in turbulent water. The polypropylene body is made with a double airtight chamber and with a re-injection sealing of melted polypropylene at high pressure to ensure perfect sealing capacity against infiltrations.



SWITCHES FOR DARK WATER

- Breaking capacity: 10(3)A / 250 Vac (ATEX II 3G approval)
- Switching angle: $\pm 45^\circ$
- Resistance to pressure: 2 bar
- Available with PVC or neoprene cable and with various lengths
- Operating temperature: $0 \div +50^\circ\text{C}$
- Storage temperature: $-20 \div +80^\circ\text{C}$
- Protection degree: IP68
- Dimensions: 177x222 mm
- Weight / Volume: 1100 g / 1000 cm³
- ENEC approval



- ATEX approval

MEASUREMENT AND CONTROL

CONNECTION DIAGRAM

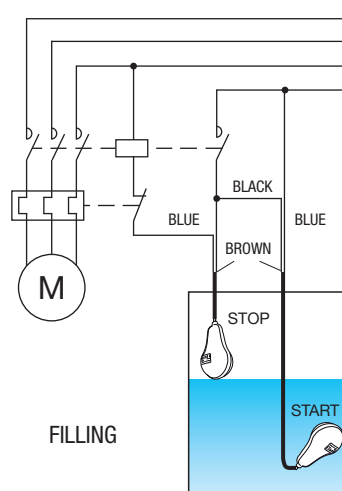

ATTENTION
The cable which is not used must be properly isolated (brown for filling blue for emptying)

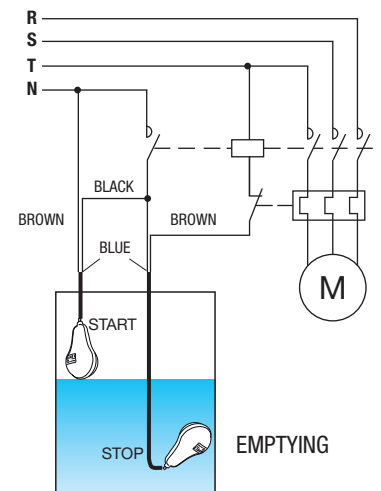

Code	Model	Description	Cable type	Length (m)
VE521100	MAC5 ATEX	Tilting level switch for dark water	Neoprene H07RN-F 3x1	5
VE522900	MAC5 ATEX	Tilting level switch for dark water	Neoprene H07RN-F 3x1	10
VE523700	MAC5 ATEX	Tilting level switch for dark water	Neoprene H07RN-F 3x1	20
VE524500	MAC5 ATEX	Tilting level switch for dark water	PVC H05VV-F 3x1	5
VE525200	MAC5 ATEX	Tilting level switch for dark water	PVC H05VV-F 3x1	10
VE526000	MAC5 ATEX	Tilting level switch for dark water	PVC H05VV-F 3x1	20