



Vemer S.p.A.
I - 32032 Feltrè (BL) • Via Camp Lonc, 16
e-mail: info@vemer.it - web site: www.vemer.it



Mod. **TIMM - R100**
TIMM - R200
TIMM - R cap
TIMM - B
TIMM - RB

User Manual

ADJUSTABLE THERMOSTAT – IMMERSION – WITH SHANK

Read all the instructions carefully

- TIMM – R100 and TIMM – R200 are boxed unipolar thermostats, liquid expansion, with switching contacts, complete with core hitch. Ideal for automatic regulation on boilers, pumps and other heating equipment. The thermostats are fixed using a 1/2" threaded trap.

SAFETY WARNINGS

CHECK THAT THE POWER IS DISCONNECTED on the USER BEING CONTROLLED before connecting the thermostat. Check that the power input is compatible with the output on the contacts (see the technical data).

Code	Model	Description
VE305900	TIMM – R100	Adjustable thermostat 30/90°C L100mm
VE306700	TIMM – R200	Adjustable thermostat 30/90°C L200mm

Dimensions

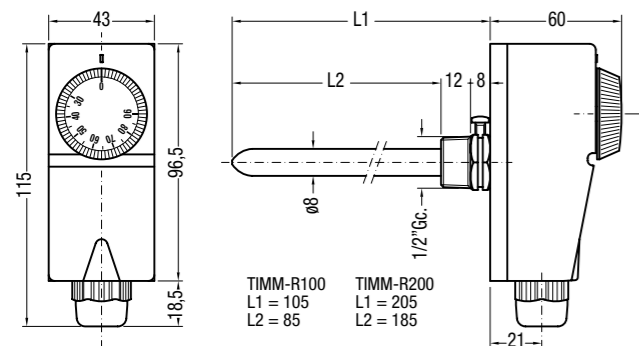

TECHNICAL DATA

- Setting range: +30 ÷ +90°C (±3°C)
- Differential: 4°C ±2°C
- Degree of protection: IP 40
- Insulation class: II
- Thermal gradient <1°C/min
- Maximum head temperature: 80°C
- Maximum bulb temperature: 110°C
- Maximum sheath pressure: 10 bar
- Change-over contacts
- Contact outputs: 16 A (5) 250 Vca
- Action type: 1B
- Core hitch: M20

INSTALLATION

- ATTENTION: only specialised electricians or authorised installers must carry out the instructions given in this leaflet, in full observance of the safety instructions and current applicable legislation.

CONNECTIONS

- Loosen the screw to remove the trap from the instrument.
- Fix the trap in the correct housing (1/2" threading).
- Replace the bulb on the thermostat inside the trap and tighten down the fixing screw.
- Slide off the knob and unscrew the two screws beneath to open the thermostat cover.
- Pass the leads through the core hitch and make the connections following the diagram below.

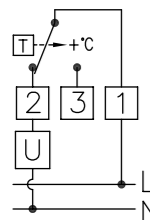

Terminal 1 = common
Terminal 2 = opens the circuit when the set temperature is reached
Terminal 3 = closes the circuit when the set temperature is reached

- Replace the cover, screws and knob.

REFERENCE STANDARDS

Conformity to the EU directive 2014/35/UE (LVD) and 2014/30/UE (EMCD) is declared in reference to the harmonised standards: EN 60730-1, EN 60730-2-9

User Manual

ADJUSTABLE THERMOSTAT – WITH EXTERNAL CAPILLARY

Read all the instructions carefully

- TIMM – R cap is a boxed unipolar thermostat, liquid expansion, with switching contacts, complete with core hitch. Ideal for automatic regulation on boilers, pumps and other heating equipment. The thermostat can be fixed on any surface using the perforated fins.

SAFETY WARNINGS

CHECK THAT THE POWER IS DISCONNECTED on the USER BEING CONTROLLED before connecting the thermostat. Check that the power input is compatible with the output on the contacts (see the technical data)

Code	Model	Description
VE307500	TIMM - R cap	Adjustable thermostat 30/90°C with extern capillary L1000mm

Dimensions

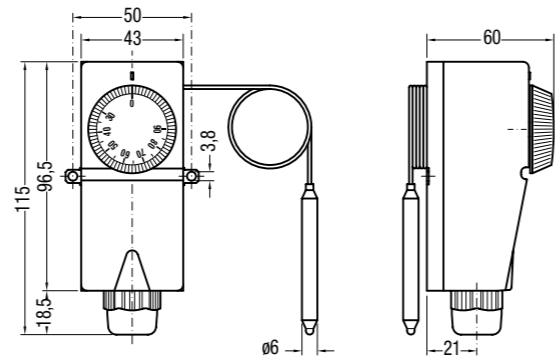

TECHNICAL DATA

- Setting range: +30 ÷ +90°C (±3°C)
- Differential: 4°C ±2°C
- Degree of protection: IP 40
- Insulation class: II
- Thermal gradient: <1°C/min
- Maximum head temperature: 80°C
- Maximum bulb temperature: 110°C
- Change-over contacts
- Contact outputs: 16 A (5) 250 Vca
- Action type: 1B
- Core hitch: M20

INSTALLATION

- ATTENTION: only specialised electricians or authorised installers must carry out the instructions given in this leaflet, in full observance of the safety instructions and current applicable legislation.

CONNECTIONS

- Fix on any surface using the perforated fins.
- Immerse the bulb at the end of the capillary in the liquid (or place it closely touching the surface) that the temperature has to be regulated for.
- Slide off the knob and unscrew the two screws beneath to open the thermostat cover.
- Pass the leads through the core hitch and make the connections following the diagram below.

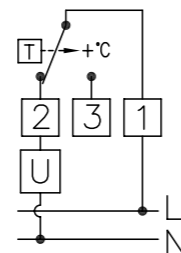

Terminal 1 = common
Terminal 2 = opens the circuit when the set temperature is reached
Terminal 3 = closes the circuit when the set temperature is reached

- Replace the cover, screws and knob.

REFERENCE STANDARDS

Conformity to the EU directive 2014/35/UE (LVD) and 2014/30/UE (EMCD) is declared in reference to the harmonised standards: EN 60730-1, EN 60730-2-9

User Manual

RESETTABLE THERMOSTAT – IMMERSION – WITH SHANK

Read all the instructions carefully

- TIMM – B is a boxed unipolar thermostat, liquid expansion, complete with core hitch. Temperature safety control with manual reset and positive security. The thermostat is fixed using a 1/2" threaded trap.

SAFETY WARNINGS

CHECK THAT THE POWER IS DISCONNECTED on the USER BEING CONTROLLED before connecting the thermostat. Check that the power input is compatible with the output on the contacts (see the technical data).

Code	Model	Description
VE308300	TIMM – B	Resettable thermostat L100mm

Dimensions

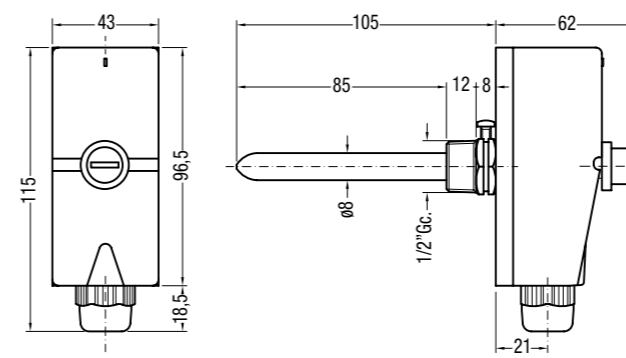

TECHNICAL DATA

- Limiter pre-set temperature: 99°C (± 4°)
- Reset manual and positive safety
- Degree of protection: IP 40
- Insulation class: II
- Thermal gradient: <1°C/min
- Maximum head temperature: 80°C
- Maximum bulb temperature: 110°C
- Maximum sheath pressure: 10 bar
- Normally closed contact
- Contact outputs: 16 A (5) 250 Vca
- Action type: 1B
- Core hitch: M20

INSTALLATION

- ATTENTION: only specialised electricians or authorised installers must carry out the instructions given in this leaflet, in full observance of the safety instructions and current applicable legislation.

CONNECTIONS

- Loosen the screw to remove the trap from the instrument.
- Fix the trap in the correct housing (1/2" threading).
- Replace the bulb on the thermostat inside the trap and tighten down the fixing screw.
- Unscrew the protection hood of the resettable push-button and the below dice to open the thermostat cover.
- Pass the leads through the core hitch and make the connections following the diagram below.

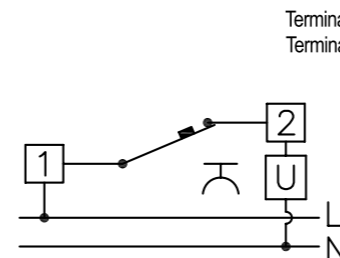

Terminal 1 = common
Terminal 2 = opens the circuit when the set temperature is reached (99°C ±4°C)

- Replace the cover, nut and gap.

RESET OPERATION

In case of activation of the reset thermostat (open contact), wait until the system temperature falls within the normal limits. Remove the causes that led to the overheating of the system. Then proceed to manually reset the thermostat by removing the plastic cap and pushing the button inside the nut with a special tool. Finally screw the cap onto the nut.

REFERENCE STANDARDS

Conformity to the EU directive 2014/35/UE (LVD) and 2014/30/UE (EMCD) is declared in reference to the harmonised standards: EN 60730-1, EN 60730-2-9

User Manual

DOUBLE RESETTABLE AND ADJUSTABLE THERMOSTAT – IMMERSION – WITH SHANK

Read all the instructions carefully

- TIMM – RB is a boxed double unipolar thermostat, liquid expansion, with switching contacts, complete with core hitches. Temperature regulator and safety control with manual reset and positive security. The thermostat is fixed using a 1/2" threaded trap.

SAFETY WARNINGS

CHECK THAT THE POWER IS DISCONNECTED on the USER BEING CONTROLLED before connecting the thermostat. Check that the power input is compatible with the output on the contacts (see the technical data).

Code	Model	Description
VE309100	TIMM – RB	Resettable and adjustable thermostat 30/90°C L100mm

Dimensions

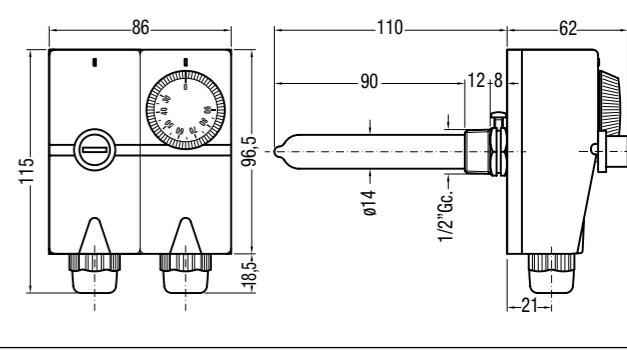

TECHNICAL DATA

- Regulator temperature setting range: +30 ÷ +90°C (± 3°C)
- Differential: 4°C ± 2°C
- Limiter pre-set temperature: +99°C (± 4°C)
- Reset: manual and positive safety
- Degree of protection: IP40
- Insulation class: II
- Thermal gradient: <1 °C/min
- Maximum head temperature: 80°C
- Maximum bulb temperature: 110°C
- Maximum sheath pressure: 10 bar
- Normally closed or change-over contacts
- Contact outputs: 16 A (5) 250 Vca
- Action type: 1B
- Core hitch M20

INSTALLATION

- ATTENTION: only specialised electricians or authorised installers must carry out the instructions given in this leaflet, in full observance of the safety instructions and current applicable legislation.

CONNECTIONS

- Loosen the screw to remove the trap from the instrument.
- Fix the trap in the correct housing (1/2" threading).
- Replace the bulbs on the double thermostat inside the trap and tighten down the fixing screw.
- To access to the limiter thermostat remove the cover and nut. To access to the regulator thermostat remove the knob and below the screws. Then remove the double plastic cover.
- Pass the leads through the core hitches. The instrument is designed to work on two independent circuits (one with the regulator and the other with the limiter), or on a single circuit with the regulator and limiter connected as shown in the following diagram.

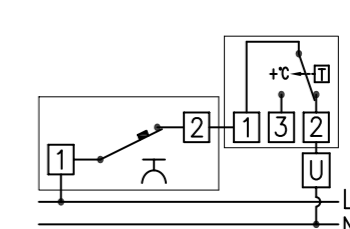

LIMITER
Terminal 1 = common
Terminal 2 = opens the circuit when the set temperature is reached (99°C ±4°C)

REGULATOR
Terminal 1 = common
Terminal 2 = opens the circuit when the set temperature is reached
Terminal 3 = closes the circuit when the set temperature is reached

- Replace the cover, screws and knob nut and cap.

RESET OPERATION

In case of activation of the reset thermostat (open contact), wait until the system temperature falls within the normal limits. Remove the causes that led to the overheating of the system. Then proceed to manually reset the thermostat by removing the plastic cap and pushing the button inside the nut with a special tool. Finally screw the cap onto the nut.

REFERENCE STANDARDS

Conformity to the EU directive 2014/35/UE (LVD) and 2014/30/UE (EMCD) is declared in reference to the harmonised standards: EN 60730-1, EN 60730-2-9



Information to users pursuant to art. 14 of the directive 2012/19 / EU of the European Parliament and of the Council of 4 July 2012 on waste electrical and electronic equipment (WEEE)

If the crossed-out bin symbol appears on the equipment or packaging, this means the product must not be included with other general waste at the end of its working life. The user must take the worn product to a sorted waste center, or return it to the retailer when purchasing a new one. Products for disposal can be consigned free of charge (without any new purchase obligation) to retailers with a sales area of at least 400 m², if they measure less than 25 cm. An efficient sorted waste collection for the environmentally friendly disposal of the used device, or its subsequent recycling, helps avoid the potential negative effects on the environment and people's health, and encourages the re-use and/or recycling of the construction materials.